

Slimline, low glare linear luminaires

Flexbar is an elegant surface mounted, suspended or recessed linear luminaire ideal for a wide range of applications. The high performance lens technology provides well-controlled low glare lighting for optimum user comfort.

Individual and continuous versions along with corner joints allow the lighting designer to be creative with their lighting layouts. Supreme efficiency (160.5 LL/CW) and 100,000 hour life ensures Flexbar has the performance to match its elegance.

Applications: offices, teaching spaces, meeting rooms, breakout areas, reception areas, circulation spaces and retail.

- Integral through wiring system with plug and socket connector versions
- TM66 score of 2.6 - LIA/CIBSE certification scheme TSD-012 verified
- White (RAL 9016) or black (RAL 9005) body finishes
- Black 'invisible' light source, metallised low glare and white reflector options
- Versions with optional uplight component
- Surface, suspended and recessed mounting options
- Magnetic clip-in light engine
- Low glare optics for EN12464-1 / LG7 (<1500cd/m² @ 65°) when using the metallised or black reflector

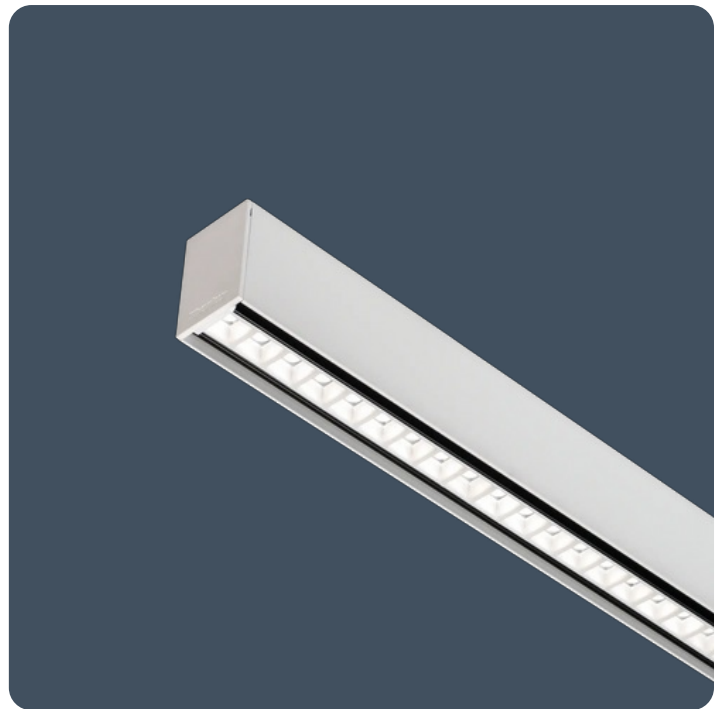

Notes: See installation leaflet for fixing locations

Up to IP40

Up to 160.5 LL/CW

TM66 circularity score 2.6

Specification

| | | | |
|--------------|------------------------------------|-------------------------------|------------|
| Mounting | Recessed Surface Suspended | IP rating | Up to IP40 |
| Nominal size | 850 x 870 mm 1400 mm 2800 mm | Max presence detection height | 8 m |

Sustainability

| | |
|------------------------|-----|
| TM66 circularity score | 2.6 |
|------------------------|-----|

Lighting

| | | | |
|--------------|----------------------|----------|-------------------|
| Lumen output | 1,195 lm - 10,710 lm | Efficacy | Up to 160.5 LL/CW |
|--------------|----------------------|----------|-------------------|

Emergency data

| | | | |
|------------------------|-----------------|-----------------------|-----------------------------|
| Emergency lumen output | 345 lm - 440 lm | Emergency type | Maintained |
| Emergency duration | 3 hours | Battery specification | Nickel Metal Hydride (NiMH) |

Power

| | | | |
|---------------|-------------|---------------------|------------|
| LED power | 8 W - 63 W | LED power per metre | 6 W - 22 W |
| Circuit power | 10 W - 71 W | | |

LED characteristics

| | | | |
|--------------------|-----------------|--------------------|--------|
| CRI | 80+ | Colour temperature | 4000 K |
| Rated life (hours) | 100 K - L80/B10 | | |

Compliance

| | | | |
|-------------------------|--|----|-------|
| UKCA | Yes | CE | Yes |
| Energy efficiency class | This product contains a light source of Thermoplastic rating energy efficiency class B | | TP(a) |

Dimensions

Suspended version

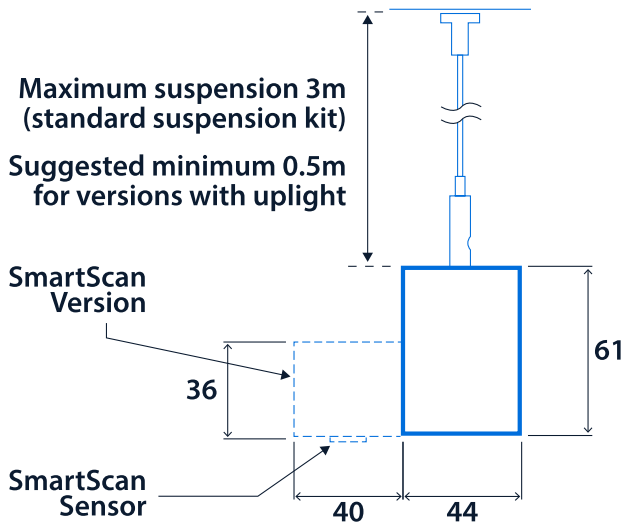

Surface version

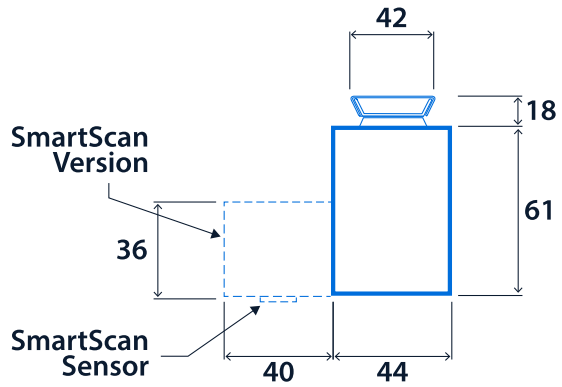

Recessed version (pull-up only)

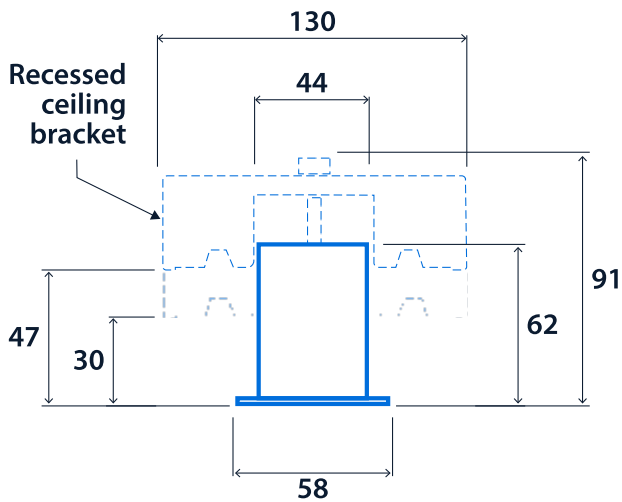

Mounting Arrangement - Plasterboard ceiling

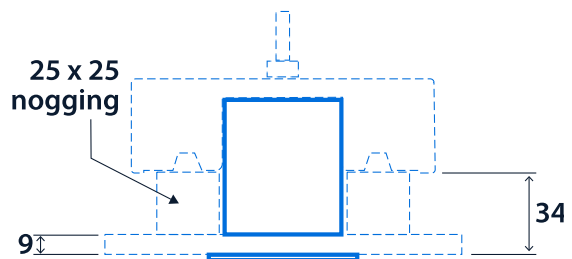

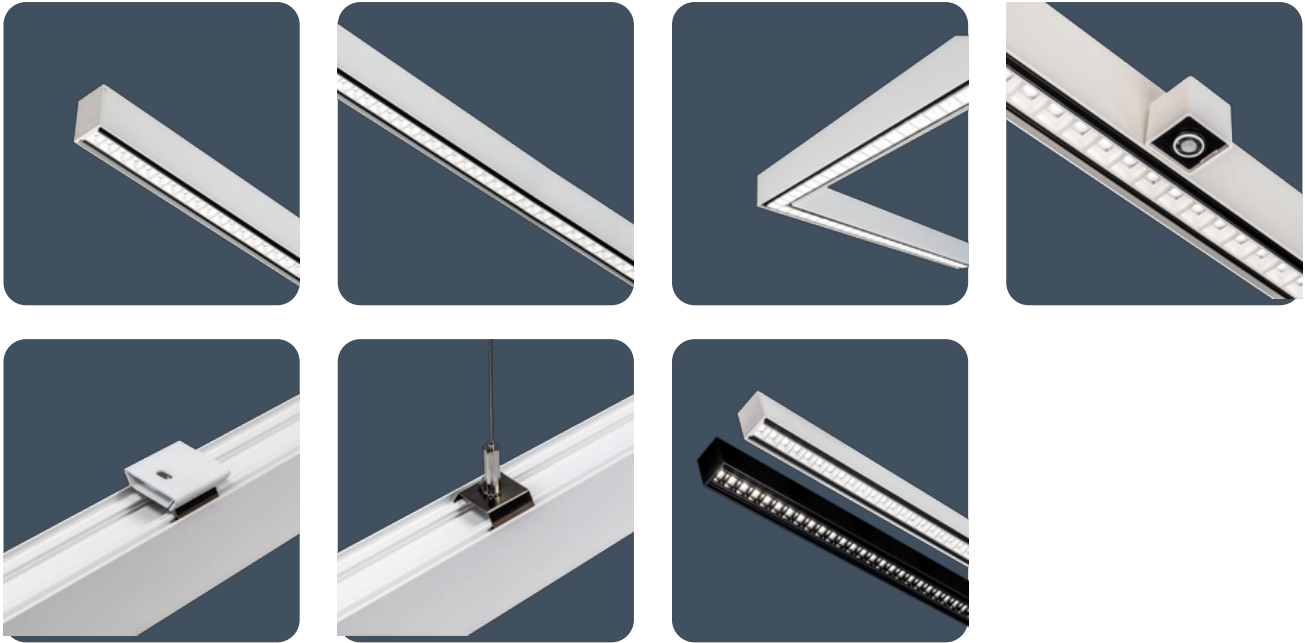

Click or scan here
View Flexbar variants using our
online filtering tool



Information is correct as of 01 Jan 2025, however must not be interpreted as a guarantee of individual product performance and/or characteristics. We reserve the right to alter specifications and designs without prior notice.